

PGL-1064-PM-R



1064 nm Programmable Picosecond PM Laser, w/Integrated Pulse Generator

The Optilab PGL-1064-PM-R is a programmable laser that produces picosecond pulses with pulse generator integrated. It functions as a seed pulse generator for Master Oscillator Power Amplifiers (MOPA). The PGL-1064- PM is designed to produce < 100 ps widths and corresponding repetition rates up to 100 MHz from the user's electrical pulse generator. It features a high Extinction Ratio (ER) Mach-Zehnder Interferometer (MZI) optical modulator with a high pulse contrast of -30 dB. The PGL-1064-PM-R consists of a narrow-line-width, ultra stable, External Cavity Laser Diode (ECLD), centered at 1064 nm transmission wavelength. The External Cavity Laser (ECL) operates under Continuous Wave (CW) mode, modulated by a high speed modulator rise time of less than 35 ps. The Automatic Bias Controller (ABC) board is used to properly maintain the bias point of the optical modulator and ensure jitter free, ultra-fast pulse generation. It features PM fiber for polarization maintaining, and is available with an optional PM EDFA to boost peak pulse power. The laser system is equipped with a standard remote control interface (RS-232) and an LCD display screen for easy user interface, accessible through a front panel adjustment knob. Contact Optilab for more information.

OVERVIEW

FEATURES

- Fixed Pulse Width of 100 ps
- High speed optical modulator w/ < 35 ps rise time
- 1064 nm Wavelength External Cavity Laser
- High Pulse Contrast of -30 dB
- Uses external electrical input
- Optional high power PM EDFA
- Collimated output available

USE IN

- Picosecond pulse generator
- Research & Development
- Testing & Measurement
- Master Oscillator Power Amplifier (MOPA)

FUNCTION DIAGRAM

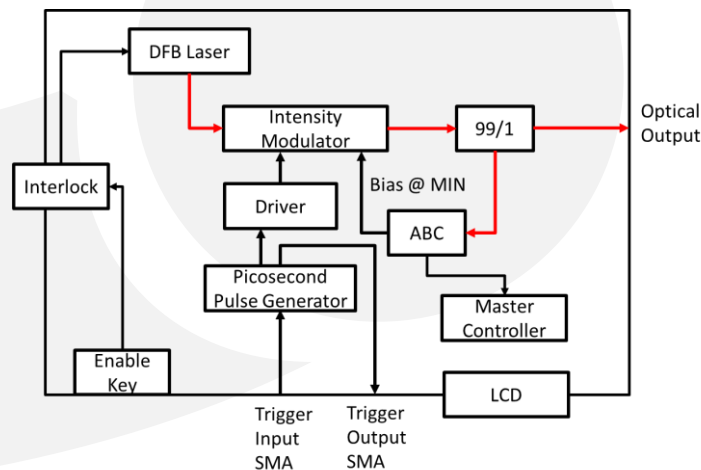

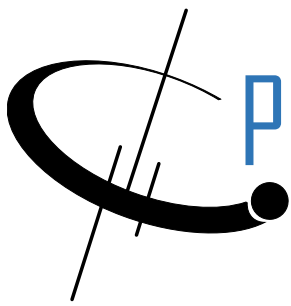

PGL-1064-PM-R

SPECIFICATIONS

Wavelength	1064 nm ± 10 nm
Wavelength Tuning Range	Up to ± 1.5 nm
Fixed Pulse Width	100 ps
Modulator Rise/Fall Time	< 35 ps
Source Laser Linewidth	5 MHz typ.
Pulse Repetition Rate	Programmable 50 KHz to 100 MHz depending upon electrical pulse input
Energy per Pulse	0.1 µJ
Pulse Contrast	-30 dB
Peak Power Output (no EDFA)	20 mW peak
Peak Power Output (w/ EDFA)	Up to 2 kW peak
Jitter Relative to RF Reference	10 rms max.
Pulse Amplitude Variation	1% rms max.
Trigger IN Amplitude	300 ~ 500 mVpp
Trigger OUT Amplitude	500 mVpp
Polarization Extinction Ratio	20 dB typ.
Amplitude Stability (short term)	-20 dB typ.
Polarization Design	Single linear polarization, slow axis passing

GENERAL

Modulator Bandwidth	Up to 20 GHz
Modulator Type	MZI with high ER ratio 40 dB
Input Level	> 0.5 V peak to peak
Pulse Repetition Rate	Programmable 50 KHz to 100 MHz
Minimal Pulse Width	< 75 ps
Trigger IN/OUT Impedance	50Ω
Electrical Input Frequency	50 KHz to 12 GHz
Electrical Connector	SMA

ELECTRICAL PULSE INPUT

Operating Temperature	0°C to +50 °C
Storage Temperature	-40°C to +70 °C
Humidity	10% to 90%
Power SuPGLy	100 V AC and 220 V AC, 50 or 60 Hz
Display	Temperature, Current, Voltage
Controls/Monitoring	LCD display
Communication Interface	RS-232 interface with optional Ethernet
Dimensions	1RU: 19" x 14" x 1.75"
Optical Connector	SMF-28 FC/APC or user option
Optical Fiber	PANDA Fiber PM
Electrical Connectors	SMA Female

MECHANICAL





PGL-1064-PM-R

OPTIONAL COLLIMATOR

Collimated Beam Quality	$m^2 < 1.5$
Nominal Beam Diameter	1.2 mm
Average Optical Power	15 W max.
Peak Power for ns Pulse	15 KW max.
Fiber Type	PLMA-GDF-25/300

OPTIONS

PGL-XXXX-Y-PM-R

XXXX Wavelength: 1064 +/- 10 nm
Y Peak Power

OPTICAL PULSE OUT

The PGL-1064-PM-R has a linear translation from electrical to optical pulses with a 1:1 ratio. The electrical and optical pulses look nearly identical.

