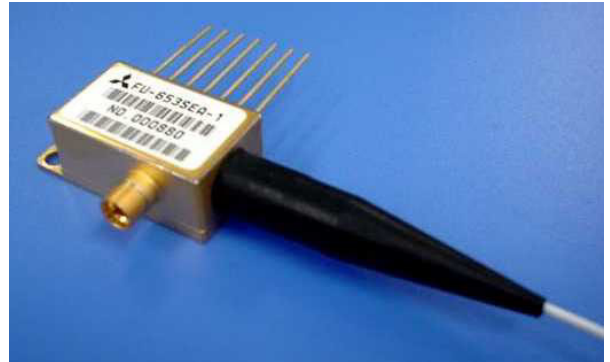

FU-653SEA-x1Mx1.55 μm EAM-LD MODULE WITH SINGLEMODE FIBER PIGTAIL**DESCRIPTION**

Module type FU-653SEA-1Mx is a 1.55 μm EA modulator integrated DFB-LD module with single-mode optical fiber. This module is suitable to a light source for use in 10Gb/s digital optical communication systems.

FEATURES

- Input impedance is 50 Ω
- Integrated Electroabsorption Modulator(EAM)
- Distributed feedback (DFB) Laser Diode
- Emission wavelength is the 1.55 μm band
- Single-mode optical fiber pig-tail
- Built-in optical isolator
- 7-pin Butterfly package with GPO connector
- Built-in thermal electric cooler

**APPLICATION**

STM-64, OC192

ABSOLUTE MAXIMUM RATINGS

Parameter		Symbol	Conditions	Rating	Unit
Laser diode	Optical output power	Pf	CW	6	mW
	Forward current	If	CW	200	mA
	Reverse voltage	Vrl	CW	2	V
Modulator	Reverse voltage	Vrm	-	5	V
	Forward voltage	Vfm	-	1	V
Photodiode for monitoring	Reverse voltage	Vrd	-	20	V
	Forward current	lfd	-	2	mA
Thermoelectric cooler(Note1)	Current	Ipe	-	1.5	A
	Voltage	Vpe	-	3	V
Operating case temperature		Tc	-	-20~70	$^{\circ}\text{C}$
Storage temperature		Tstg	-	-40~85	$^{\circ}\text{C}$

Note)

Even if the thermoelectric cooler (TEC) is operated within the rated conditions, uncontrolled current loading or operation without heat sink may easily damage the module by exceeding the storage temperature range. Thermistor resistance should be properly monitored by the feedback circuit during TEC operation to avoid the catastrophic damage.

FU-653SEA-x1Mx1.55 μm EAM-LD MODULE WITH SINGLEMODE FIBER PIGTAIL**ELECTRICAL/OPTICAL CHARACTERISTICS** (T_{ld}=T_{set}, T_c=25°C unless otherwise noted)

Parameter	Symbol	Conditions(Note2)	Min.	Typ.	Max.	Unit	
Threshold current	I _{th}	CW, V _m =0V	5	-	30	mA	
Operating current	I _{op}	CW, V _m =0V	50	70	100	mA	
Operating voltage	V _{op}	CW, I _f =I _{op} , V _m =0V	-	-	1.7	V	
Input impedance	Z _{in}	I _f =I _{op}	-	50	-	Ω	
Optical output power from fiber end	P _f	(Note 3,4)	-1	-	-	dBm	
Wavelength	λ_c	(Note 3,4)	1530	1550	1565	nm	
Side mode suppression ratio	S _r	(Note 3,4)	35	40	-	dB	
Relative intensity noise	RIN	CW, I _f =I _{op} , V _m =0V, 10GHz	-	-	-135	dB/Hz	
Dispersion penalty	P _p	(Note 3,4), 130ps/nm	-	-	1.0	dB	FU-653SEA-1M1
		(Note 3,4), 800ps/nm	-	-	2.0	dB	FU-653SEA-1M2
		(Note 3,4), 36ps/nm	-	-	1.0	dB	FU-653SEA-1M3
		(Note 3,4), 500ps/nm	-	-	2.0	dB	FU-653SEA-1M4
Extinction ratio	Ex	(Note 3,4)	10	-	-	dB	
Rise/fall time	tr/ta	(Note 3,4), 20-80%	-	-	45	ps	
Cutoff frequency	f _c	I _f =I _{op} , V _m =-1V	10	-	-	GHz	
RF return loss	S ₁₁	I _f =I _{op} , V _m =-1V, f \leq 5GHz	10	15	-	dB	
		I _f =I _{op} , V _m =-1V, f \leq 10GHz	5	7	-	dB	
Tracking error	E _r	I _f =I _{op} , T _c =-20~70°C, Note 5	-	0.3	0.5	dB	
Monitor current	I _{mon}	I _f =I _{op} , V _{rd} =-5V	0.1	-	1.5	mA	
Dark current(PD)	I _d	V _{rd} =-5V	-	-	0.1	μA	
Capacitance(PD)	C _t	V _{rd} =-5V	-	10	-	pF	
Optical isolation	I _{so}	T _c =25°C	35	-	-	dB	
		T _c =-20~70°C	23	-	-	dB	

Note 2 : V_m is EAM bias voltage at CW condition, V_{pp} and V_{off} are EAM amplitude and EAM high level offset voltage respectively at modulation condition.

Note 3 : 9.95328Gbps, NRZ, PRBS2²³-1, I_f=I_{op}, V_{pp}=2.5V, V_{off}=0~ -1.0V

Note 4 : Optical return loss of the connectors should be greater than 40dB in order to get specified performance.

Note 5 : E_r=max|10 \times log(P_f/P_{f@25°C})|

THERMAL CHARACTERISTICS

Parameter	Symbol	Conditions (Note2)	Limits			Unit
			Min.	Typ.	Max.	
Thermistor resistance	R _{th}	T _c =25°C,	9.5	10	10.5	Ω
B constant of R _{th}	-	-	-	3950	-	K
Cooler current	I _{pe}	I _f =I _{op} , T _c =70°C	-	0.7	1.2	A
Cooler voltage	V _{pe}	I _f =I _{op} , T _c =70°C	-	1.7	2.5	V

FIBER PIGTAIL SPECIFICATIONS

Parameter	Specification	Unit
Type	SM	-
Mode field diameter	9.5 \pm 1	μm
Cladding diameter	125 \pm 2	μm
Secondary coating outer diameter	0.9 \pm 0.1	mm
Connector	See fig.1	-
Optical return loss of connector	40(min)	dB

FU-653SEA-x1Mx

1.55 μm EAM-LD MODULE WITH SINGLEMODE FIBER PIGTAIL

OUTLINE DIAGRAM

Unit : mm

NOTES 1. TOLERANCES UNLESS NOTED ±0.5mm

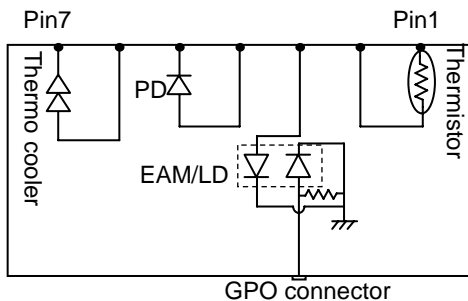
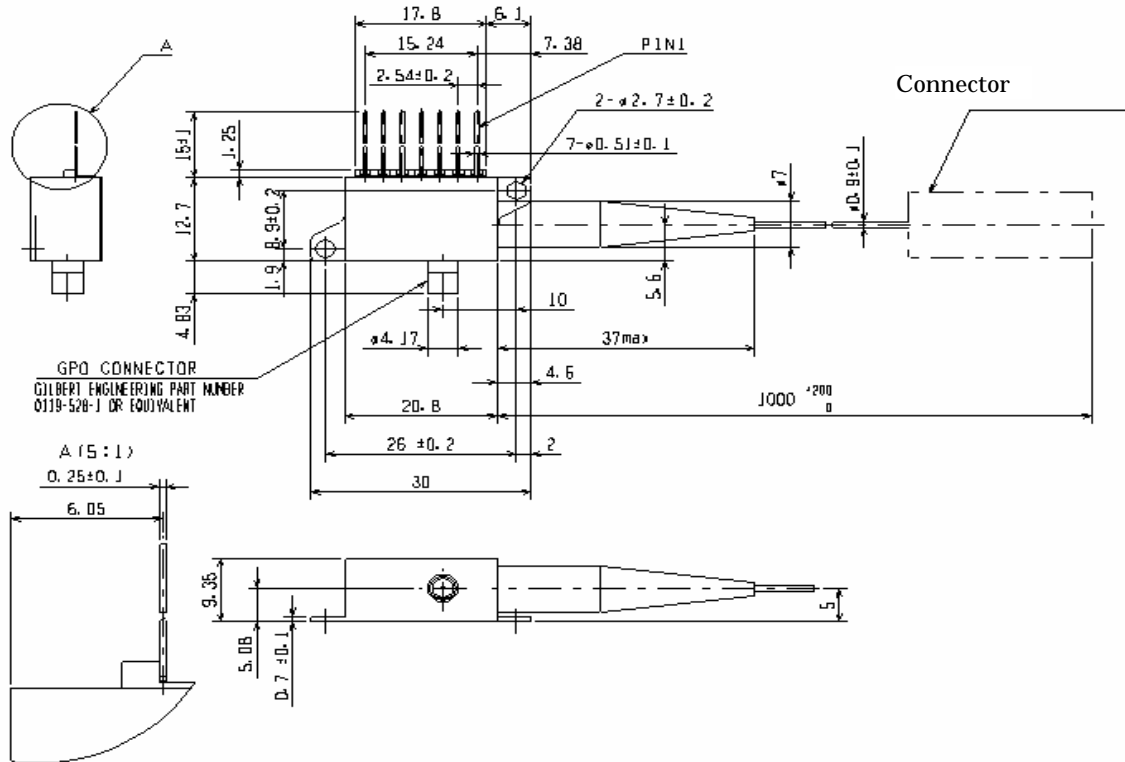

Pin No.	Function
1	Thermistor
2	Thermistor
3	LD bias (Anode)
4	Monitor PD (Anode)
5	Monitor PD (Cathode)
6	Cooler (Anode)
7	Cooler (Cathode)
Case	Ground

Connector type	Identical type number	Dispersion
No connector	FU-653SEA-1M1	130ps/nm
	FU-653SEA-1M2	800ps/nm
	FU-653SEA-1M3	36ps/nm
	FU-653SEA-1M4	500ps/nm
FC/PC	FU-653SEA-V1M1	130ps/nm
	FU-653SEA-V1M2	800ps/nm
	FU-653SEA-V1M3	36ps/nm
	FU-653SEA-V1M4	500ps/nm
SC/PC	FU-653SEA-W1M1	130ps/nm
	FU-653SEA-W1M2	800ps/nm
	FU-653SEA-W1M3	36ps/nm
	FU-653SEA-W1M4	500ps/nm

FU-653SEA-1M1/-1M2/-1M3/-1M4

FU-653SEA-x1Mx1.55 μm EAM-LD MODULE WITH SINGLEMODE FIBER PIGTAIL**Safety Cautions for Use of Optoelectronic Devices****General:**

Although the manufacturer is always striving to improve the reliability of its product, problems and errors may occur with semiconductor products. Therefore, the user's products are required to be designed with full safety regard to prevent any accidents that results in injury, death, fire or environmental damage even when semiconductor products happen to error. Especially it is recommended to take in consideration about redundancy, fire prevention, error prevention safeguards. And the following requirements must be strictly observed.

Warning!

1. Eye safety : Semiconductor laser radiates laser light during operation. Laser light is very dangerous when shot directly into human eyes. Don't look at laser light directly, or through optics such as a lens. The laser light should be observed using the ITV camera, IR-viewer, or other appropriate instruments.

2. Product handling : The product contains GaAs (gallium arsenide). It is safe for regular use, but harmful to the human body if made into powder or steam. Be sure to avoid dangerous process like smashing, burning, chemical etching. Never put this product in one's mouth or swallow it.

3. Product disposal : This product must be disposed of as special industrial waste. It is necessary to separate it from general industrial waste and general garbage.

Handling Cautions for Optoelectronic Devices**1. General:**

(1) The products described in this specification are designed and manufactured for use in general communication systems or electronic devices, unless their applications or reliability are otherwise specified. Therefore, they are not designed or manufactured for installation in devices or systems that may affect human life or that are used in social infrastructure requiring high reliability.

(2) When the customer is considering to use the products in special applications, such as transportation systems (automobiles, trains, vessels), medical equipments, aerospace, nuclear power control, and submarine repeaters or systems, please contact Mitsubishi Electric or an authorized distributor.

2. Shipping Conditions:

(1) During shipment, place the packing boxes in the correct direction, and fix them firmly to keep them immovable. Placing the boxes upside down, tilting, or applying abnormal pressure onto them may cause deformation in the electrode terminals, breaking of optical fiber, or other problems.

(2) Never throw or drop the packing boxes. Hard impact on the boxes may cause break of the devices.

(3) Take strict precautions to keep the devices dry when shipping under rain or snow.

3. Storage Conditions:

When storing the products, it is recommended to store them following the conditions described below without opening the packing. Not taking enough care in storing may result in defects in electrical characteristics, soldering quality, visual appearance, and so on. The main points are described below (if special storage conditions are given to the product in the specification sheet, they have priority over the following general cautions):

(1) Appropriate temperature and humidity conditions, i.e., temperature range between 5~30 °C, and humidity between 40~60 percent RH, should be maintained in storage locations. Controlling the temperature and humidity within this range is particularly important in case of long-term storage for six months or more.

(2) The atmosphere should be particularly free from toxic gases and dust.

(3) Do not apply any load on the product.

(4) Do not cut or bend the leads of the devices which are to be stored. This is to prevent corrosion in the cut or bent part of the lead causing soldering problems in the customer's assembling process.

(5) Sudden change in temperature may cause condensation in the product or packing, therefore, such locations should be avoided for storing. Temperature in storage locations should be stable.

(6) When storing ceramic package products for extended periods of time, the leads may turn reddish due to reaction with sulfur in the atmosphere.

(7) Storage conditions for bare chip and unsealed products shall be stated separately because bare chip and unsealed products require stricter controls than package sealed products.

4. Design Conditions and Environment under Use:

(1) Avoid use in locations where water or organic solvents adhere directly to the product, or where there is any possibility of the generation of corrosive gas, explosive gas, dust, salinity, or other troublesome conditions. Such environments will not only significantly lower the reliability, but also may lead to serious accidents.

(2) Operation in excess of the absolute maximum ratings can cause permanent damage to the device. The customers are requested to design not to exceed those ratings even for a short time.

5. ESD Safety Cautions:

The optoelectronic devices are sensitive to static electricity (ESD, electro-static discharge). The product can be broken by ESD. When handling this product, please observe the following countermeasures:

<Countermeasures against Static Electricity and Surge>

To prevent break of devices by static electricity or surge, please adopt the following countermeasures in the assembly line:

(1) Ground all equipments, machinery jigs, and tools in the process line with earth wires installed in them. Take particular care with hot plates, solder irons and other items for which the commercial power supplies are prone to leakage.

(2) Workers should always use earth bands. Use of antistatic clothing, electric conductive shoes, and other safety equipment while at work is highly recommended.

(3) Use conductive materials for this product's container, etc.

(4) It is recommended that grounding mats be placed on the surfaces of assembly line workbench and the surrounding floor in work area, etc.

(5) When mounting this product in parts or materials which can be electrically charged (printed wiring boards, plastic products, etc.), pay close attention to the static electricity in those parts. ESD may damage the product.

(6) Humidity in working environment should be controlled to be 40 percent RH or higher.

These countermeasures are most general, and there is a need to carefully confirm the line before starting mass production using this product (in the trial production, etc.). It is extremely important to prevent surge, eliminate it rapidly, and prevent it from spreading.